



# Kaspersky Industrial CyberSecurity for Siemens SPPA-T3000

kaspersky

# Kaspersky Industrial CyberSecurity for SPPA-T3000

Siemens has handled power plant engineering, design, and construction in-house for decades, and is intimately familiar with all the tasks surrounding power plant automation. Having successfully automated more than 3,000 units worldwide over the past 50 years, Siemens has the most extensive automation experience in the power plant market.

Kaspersky is a global cybersecurity company founded more than 20 years ago. Kaspersky's deep threat intelligence and security expertise is constantly transforming into innovative security solutions and services to protect businesses, critical infrastructure, governments and consumers. Over 400 million users and 270,000 corporate clients are protected by Kaspersky technologies around the globe.

## SPPA-T3000

The synergy provided by the application of Kaspersky Industrial CyberSecurity (KICS) protection software for workstations with in the SPPA-T3000 environment makes industrial processes resilient, efficient and safe. The SPPA-T3000 design is tailored to power generation – with specific electronic technology, control algorithms, function libraries, and concepts developed on Siemens deep plant expertise, and focused on time-proven standards. You can build on this strong foundation over the long term because Siemens expertise flows into continuous advances. Benefit from long-term support, when and where you need it.

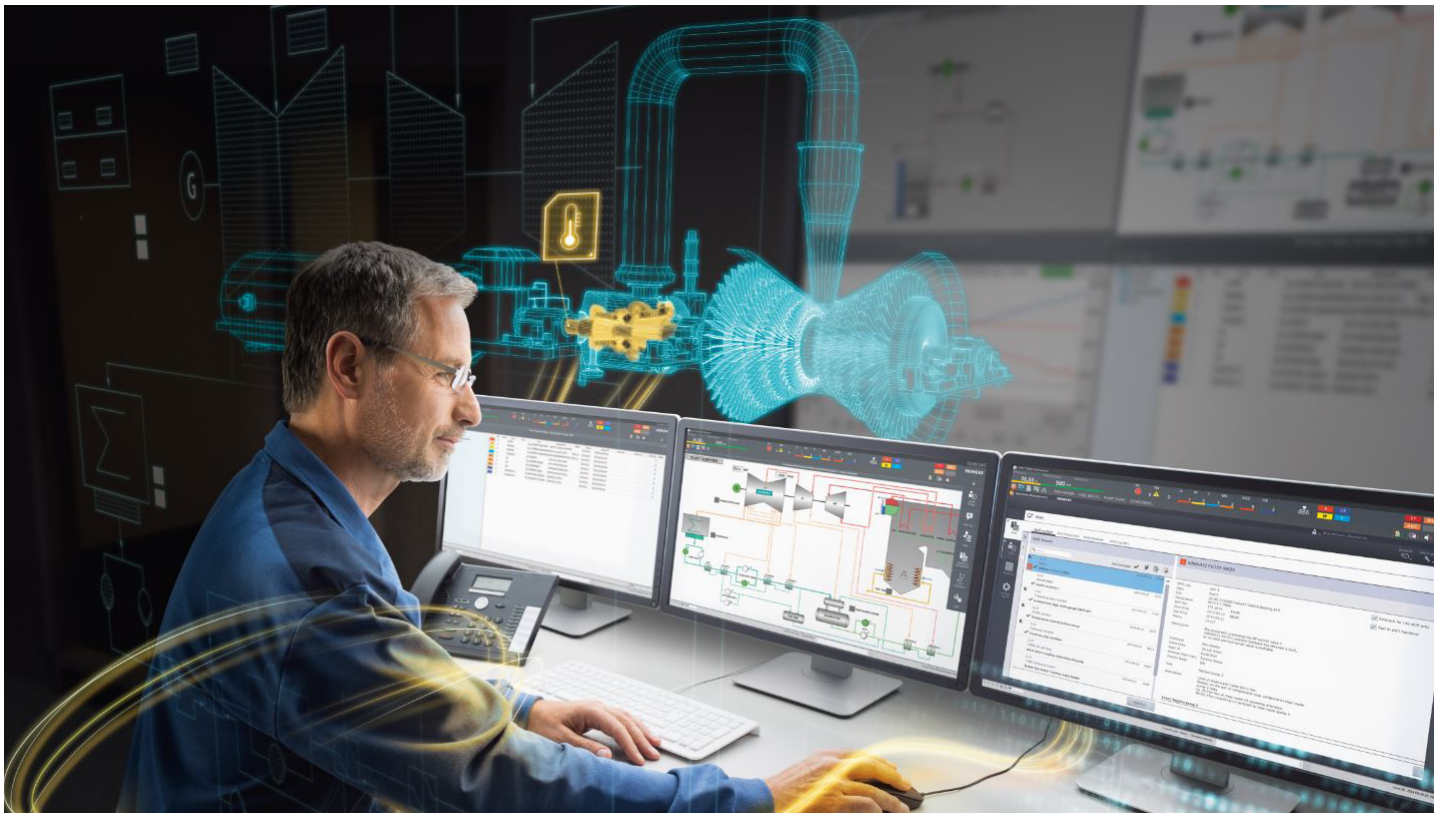

# KICS for Nodes

KICS for Nodes was designed as industrial endpoint protection software to specifically address threats at the operator level in ICS environments. It secures ICS/SCADA servers, HMIs and engineering workstations from the various cyberthreats. KICS for Nodes is compatible with both the software and hardware components of industrial automation systems, such as SCADA, PLC and DCS.

## Kaspersky in SPPA-T3000

In some SPPA-T3000 solutions, Kaspersky malware protection will be installed to protect workstations from the various types of cyberthreats that can result from human factors, generic malware, targeted attacks or sabotage. Siemens has tested the compatibility of Kaspersky Industrial CyberSecurity for Nodes within the SPPA-T3000 in real environments and Siemens will release these revisions directly to its SPPA-T3000 customers in Russian Federation, Republic of Belarus, Republic of Kazakhstan, Republic of Tajikistan, Republic of Uzbekistan, Republic of Kyrgyzstan, Republic of Turkmenistan.

KICS for Nodes  
Defense in Depth model

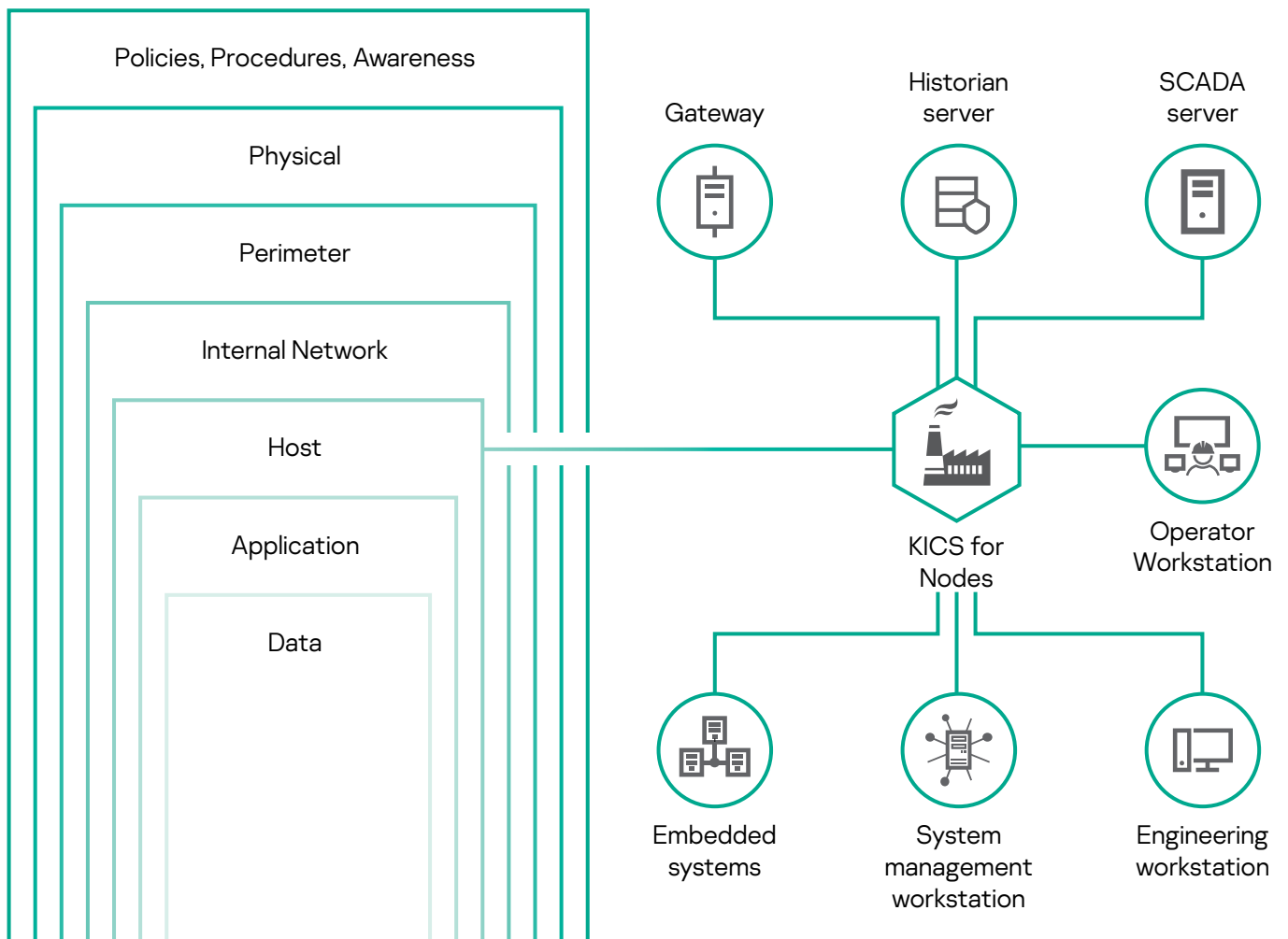

# Benefits provided by OEM

Trusted OEM integration is going beyond cost efficiency and now provides a top-level of customer experience:

- Technical and engineering support from the vendor
- Minimal response time to enquiries
- Security assurance
- 100% compatibility

## KICS for Nodes integration to SPPA T-3000

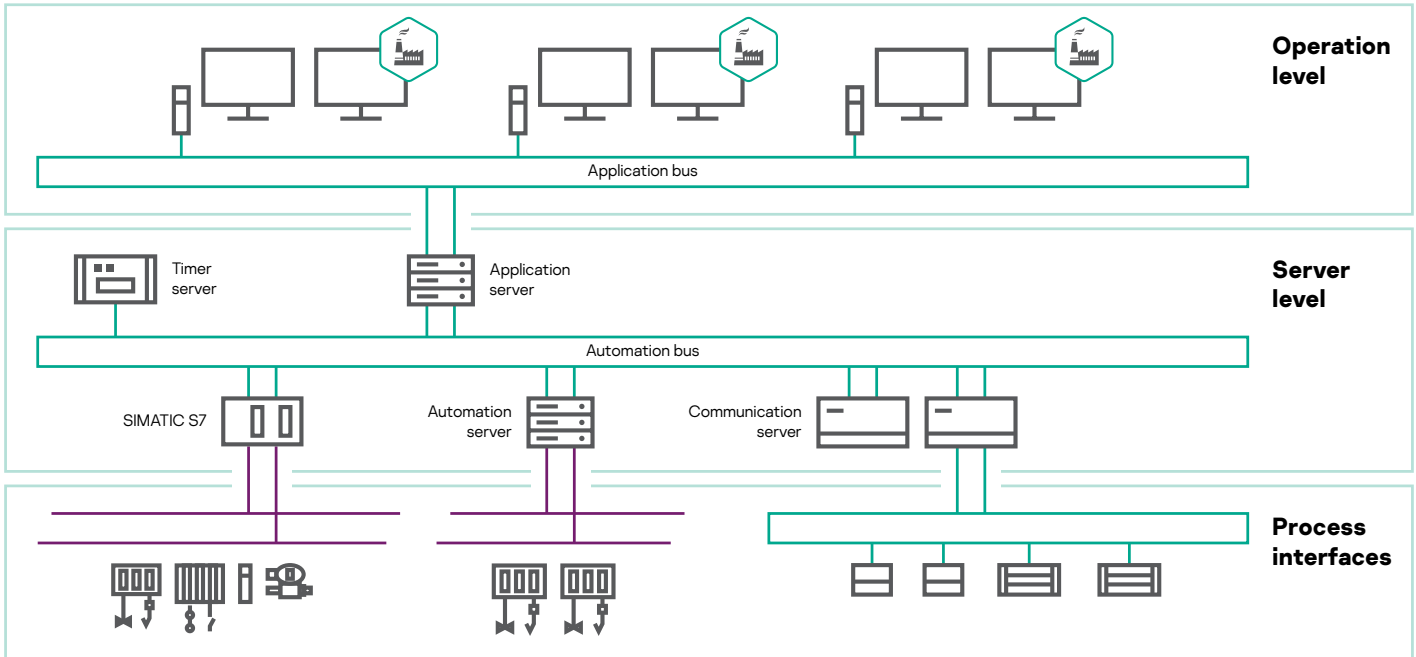

## Value for business

In addition to the technical benefits provided by OEM, Siemens and Kaspersky help businesses make more effective and efficient investments:

- **Return on investment**  
KICS embedded in SPPA-T3000 helps save money at the first stage of investment, maintain smooth operation and performance and reduce downtime in the long term.
- **Compliance**  
Kaspersky Industrial CyberSecurity for Nodes is certified by FSTEC of Russia. This confirms the compliance of the control system with the requirements and internal standards of the largest Russian companies, which place high demands on the protective equipment used at critical infrastructure facilities.



Kaspersky  
Industrial  
CyberSecurity

Kaspersky Industrial CyberSecurity is a portfolio of technologies and services designed to secure operational technology layers and elements of your organization - including SCADA servers, HMIs, engineering workstations, PLCs, network connections and even engineers - without impacting on operational continuity and the consistency of technological process.

Learn more at [www.kaspersky.com/ics](http://www.kaspersky.com/ics)



Kaspersky Industrial CyberSecurity:  
[www.kaspersky.com/ics](http://www.kaspersky.com/ics)  
Cyber Threats News: [www.securelist.com](http://www.securelist.com)

[www.kaspersky.com](http://www.kaspersky.com)

2019 AO Kaspersky Lab. All rights reserved.  
Registered trademarks and service marks are the property of their  
respective owners.